

**PROPRIETARY NOTE**

THIS SPECIFICATION IS THE PROPERTY OF BOE CQ AND SHALL NOT BE REPRODUCED OR COPIED WITHOUT THE WRITTEN PERMISSION OF BOE CQ AND MUST BE RETURNED TO BOE CQ UPON ITS REQUEST

1

**TITLE : NT156FHM-N41**

**Product Specification**

**Rev. 0**

**Chongqing BOE Optoelectronics Technology Co., Ltd**

SPEC. NUMBER	PRODUCT GROUP	Rev.	ISSUE DATE	PAGE
B2014-Q011-O (1/3)	TFT-LCD	0	2016.01.12	1 OF 32

B2014-Q011-O (1/3)

A4(210 X 297)



**BOE**

PRODUCT GROUP

REV

ISSUE DATE

Customer SPEC

Rev. 0

2016.01.12

## Contents

No.	Items	Page
1.0	General Description	4
2.0	Absolute Maximum ratings	6
3.0	Electrical specifications.	7
4.0	Optical specifications.	9
5.0	Interface Connection	14
6.0	Signal Timing Specification	17
7.0	Input Signals, Display Colors & Gray Scale of Colors	19
8.0	Power Sequence	20
9.0	Connector description	21
10.0	Mechanical Characteristics	25
11.0	Reliability Test	23
12.0	Handling & Cautions.	23
13.0	Label	24
14.0	Packing information	26
15.0	Mechanical Outline Dimension	27
16.0	EDID Table	29

SPEC. NUMBER

SPEC. TITLE

PAGE

NT156FHM-N41 Product Specification Rev. 0

3 OF 32

B2014-Q011-O (3/3)

A4(210 X 297)

**BOE**

PRODUCT GROUP

REV

ISSUE DATE

Customer SPEC

Rev. 0

2016.01.12

## 1.0 GENERAL DESCRIPTION

### 1.1 Introduction

NT156FHM-N41 is a color active matrix TFT LCD module using amorphous silicon TFT's (Thin Film Transistors) as an active switching devices. This module has a 15.6 inch diagonally measured active area with Full-HD resolutions (1920 horizontal by 1080 vertical pixel array). Each pixel is divided into RED, GREEN, BLUE dots which are arranged in vertical Stripe and this module can display 262,144 colors. The TFT-LCD panel used for this module is a low reflection and higher color type. Therefore, this module is suitable for Notebook PC. The LED Driver for back-light driving is built in this model. All input signals are eDP1.2 interface compatible.

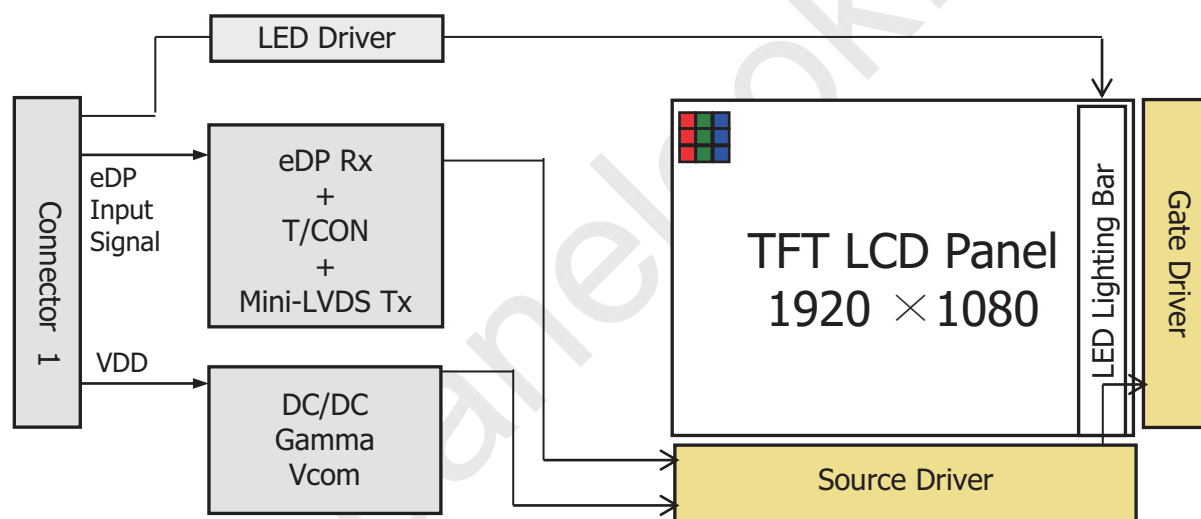

### 1.2 Features

- 2 lane eDP Interface with 2.7Gbps Link Rates
- Thin and light weight
- 6-bit color depth
- Single LED Lighting Bar. (Bottom side/Horizontal Direction)
- Data enable signal mode
- Side Mounting Frame
- Green Product (RoHS & Halogen free product)
- On board LED Driving circuit
- Low driving voltage and low power consumption
- On board EDID chip

SPEC. NUMBER

SPEC. TITLE

PAGE

NT156FHM-N41 Product Specification Rev. 0

4 OF 32

B2014-Q011-O (3/3)

A4(210 X 297)

**BOE**

PRODUCT GROUP

REV

ISSUE DATE

Customer SPEC

Rev. 0

2016.01.12

**1.3 Application**

- Notebook PC (Wide type)

**1.4 General Specification**

The followings are general specifications at the model NT156FHM-N41. (listed in Table 1.)

&lt;Table 1. General Specifications&gt;

Parameter	Specification	Unit	Remarks
Active area	344.16(H) × 193.59(V)	mm	
Number of pixels	1920 (H) × 1080 (V)	pixels	
Pixel pitch	0.17925(H) × 0.17925(V)	mm	
Pixel arrangement	RGB Vertical stripe		
Display colors	6bit		
Display mode	Normally White		
Dimensional outline	359.5 (H) × 206.5(V) × 3.2 (D:max)	mm	
Weight	370(max)	g	
Surface treatment	Anti-Glare / Hard coating		
Back-light	Bottom edge side, 1-LED Lighting Bar type		Note 1
Power consumption	<b>P<sub>D</sub> : 0.8</b>	W	Note 2
	<b>P<sub>BL</sub> : 2.6</b>	W	
	<b>P<sub>total</sub> : 3.4</b>	W	

Notes : 1. LED Lighting Bar (36\*LED Array)

Notes: 2. Maximum Measurement Condition :Mosaic Pattern

SPEC. NUMBER

SPEC. TITLE

PAGE

NT156FHM-N41 Product Specification Rev. 0

5 OF 32

B2014-Q011-O (3/3)

A4(210 X 297)

**BOE**

PRODUCT GROUP

REV

ISSUE DATE

Customer SPEC

Rev. O

2016.01.12

## 2.0 ABSOLUTE MAXIMUM RATINGS

The followings are maximum values which, if exceed, may cause faulty operation or damage to the unit. The operational and non-operational maximum voltage and current values are listed in Table 2.

&lt; Table 2. Absolute Maximum Ratings &gt;

Ta=25+/-2°C

Parameter	Symbol	Min.	Max.	Unit	Remarks
Power Supply Voltage	V <sub>DD</sub>	-0.3	4.0	V	Note 1
Logic Supply Voltage	V <sub>IN</sub>	V <sub>SS</sub> -0.3	V <sub>DD</sub> +0.3	V	
Operating Temperature	T <sub>OP</sub>	0	+50	°C	Note 2
Storage Temperature	T <sub>ST</sub>	-20	+60	°C	

- Notes : 1. Permanent damage to the device may occur if maximum values are exceeded functional operation should be restricted to the condition described under normal operating conditions.
2. Temperature and relative humidity range are shown in the figure below.  
 95 % RH Max. ( 40 °C ≥ Ta)  
 Maximum wet - bulb temperature at 39 °C or less. (Ta > 40 °C) No condensation.

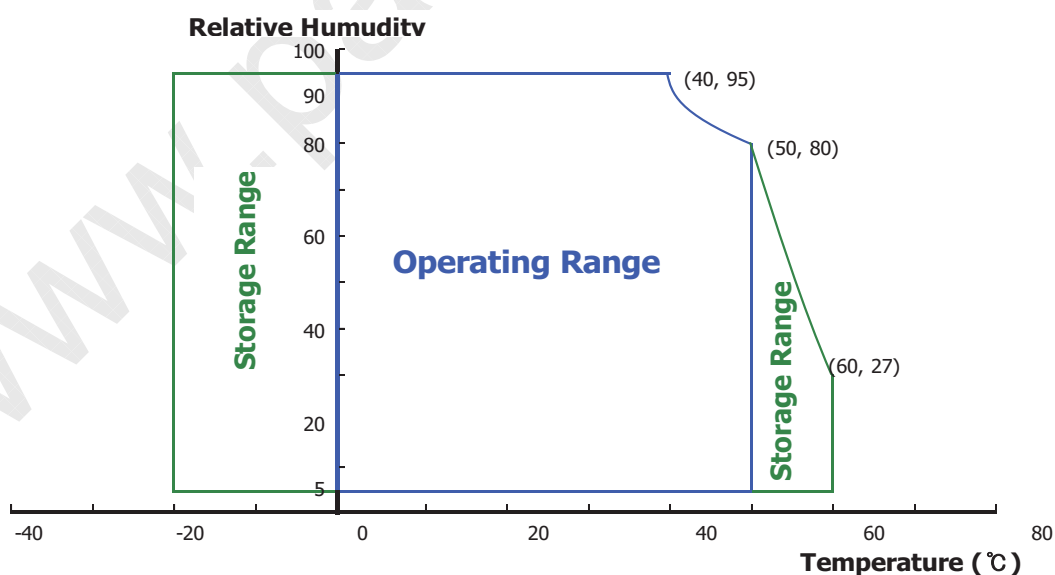

SPEC. NUMBER

SPEC. TITLE

PAGE

NT156FHM-N41 Product Specification Rev. O

6 OF 32

B2014-Q011-O (3/3)

A4(210 X 297)

**BOE**

PRODUCT GROUP

REV

ISSUE DATE

Customer SPEC

Rev. O

2016.01.12

**3.0 ELECTRICAL SPECIFICATIONS****3.1 Electrical Specifications**

&lt; Table 3. Electrical specifications &gt;

Ta=25+/-2°C

Parameter		Min.	Typ.	Max.	Unit	Remarks
Power Supply Voltage	V <sub>DD</sub>	3.0	3.3	3.6	V	Note 1
Permissible Input Ripple Voltage	V <sub>RF</sub>	-	-	100	mV	At V <sub>DD</sub> = 3.3V
Power Supply Current	I <sub>DD</sub>	-	245	550	mA	Note 1
Positive-going Input Threshold Voltage	V <sub>IT+</sub>	-	-	100	mV	V <sub>cm</sub> = 1.2V typ.
Negative-going Input Threshold Voltage	V <sub>IT-</sub>	-100	-	-	mV	
Differential Input Voltage	V <sub>ID</sub>	200	-	600	mV	
Power Consumption	P <sub>D</sub>	-	0.8	1.82	W	Note 1
	P <sub>BL</sub>	-	-	2.6	W	Note 2
	P <sub>total</sub>	-	-	4.42	W	

Notes : 1. The supply voltage is measured and specified at the interface connector of LCM.

The current draw and power consumption specified is for 3.3V at 25°C.

a) Typ : Mosaic Pattern 8\*8

b) Max : skip subpixel 255

2. Calculated value for reference (V<sub>LED</sub> × I<sub>LED</sub>)

SPEC. NUMBER

SPEC. TITLE

PAGE

NT156FHM-N41 Product Specification Rev. O

7 OF 32

B2014-Q011-O (3/3)

A4(210 X 297)

**BOE**

PRODUCT GROUP

REV

ISSUE DATE

Customer SPEC

Rev. 0

2016.01.12

**3.2 Backlight Unit**

&lt; Table 4. LED Driving guideline specifications &gt;

Ta=25+/-2°C

Parameter		Min.	Typ.	Max.	Unit	Remarks
LED Forward Voltage	$V_F$	-	-	3.0	V	-
LED Forward Current	$I_F$	-	20.3		mA	-
LED Power Consumption	$P_{LED}$		-	2.6	W	Note 1
LED Life-Time	N/A	15,000	-	-	Hour	$I_F = 20.3mA$
Power supply voltage for LED Driver	$V_{LED}$	5	12	20	V	
EN Control Level	Backlight on	2.5		5.0	V	
	Backlight off	0		1.0	V	
PWM Control Level	PWM High Level	2.5		5.0	V	
	PWM Low Level	0		0.1	V	
PWM Control Frequency	$F_{PWM}$	200	-	10,000	Hz	
Duty Ratio	-	1	-	100	%	Note3

Notes : 1. Power supply voltage 12V for LED Driver,

Calculator Value for reference  $I_F \times V_F \times 36 / \text{Driver efficiency} = P_{LED}$ 

2. The LED Life-time define as the estimated time to 50% degradation of initial luminous.

3. 1% duty cycle is achievable with a dimming frequency less than 1KHz.

SPEC. NUMBER

SPEC. TITLE

PAGE

NT156FHM-N41 Product Specification Rev. 0

8 OF 32

B2014-Q011-O (3/3)

A4(210 X 297)



**BOE**

PRODUCT GROUP

REV

ISSUE DATE

Customer SPEC

Rev. O

2016.01.12

## 4.0 OPTICAL SPECIFICATION

### 4.1 Overview

The test of Optical specifications shall be measured in a dark room (ambient luminance  $\leq 1$  lux and temperature =  $25 \pm 2^\circ\text{C}$ ) with the equipment of Luminance meter system (Goniometer system and TOPCON BM-5) and test unit shall be located at an approximate distance 50cm from the LCD surface at a viewing angle of  $\theta$  and  $\Phi$  equal to  $0^\circ$ . We refer to  $\theta\Phi=0$  ( $=\theta_3$ ) as the 3 o'clock direction (the "right"),  $\theta\Phi=90$  ( $=\theta_{12}$ ) as the 12 o'clock direction ("upward"),  $\theta\Phi=180$  ( $=\theta_9$ ) as the 9 o'clock direction ("left") and  $\theta\Phi=270$  ( $=\theta_6$ ) as the 6 o'clock direction ("bottom"). While scanning  $\theta$  and/or  $\Phi$ , the center of the measuring spot on the Display surface shall stay fixed. The backlight should be operating for 30 minutes prior to measurement. VDD shall be  $3.3 \pm 0.3\text{V}$  at  $25^\circ\text{C}$ . Optimum viewing angle direction is 6 'clock.

### 4.2 Optical Specifications

&lt;Table 5. Optical Specifications&gt;

Parameter		Symbol	Condition	Min.	Typ.	Max.	Unit	Remark
Viewing Angle range	Horizontal	$\Theta_3$	CR > 10	40	45	-	Deg.	Note 1
		$\Theta_9$		40	45	-	Deg.	
	Vertical	$\Theta_{12}$		15	20	-	Deg.	
		$\Theta_6$		30	40	-	Deg.	
Luminance Contrast ratio		CR	$\Theta = 0^\circ$	400	500			Note 2
Luminance of White	5 Points	$Y_w$	$\Theta = 0^\circ$ I <sub>LED</sub> = 20.3mA	187	220	-	cd/m <sup>2</sup>	Note 3
White Luminance uniformity	5 Points	$\Delta Y_5$		80	-	-		Note 4
	13 Points	$\Delta Y_{13}$		60	-	-		
White Chromaticity		$x_w$	$\Theta = 0^\circ$	0.283	0.313	0.343		Note 5
		$y_w$		0.299	0.329	0.359		
Reproduction of color	Red	$x_R$	$\Theta = 0^\circ$	-0.03	0.590	+0.03		
		$y_R$			0.350			
	Green	$x_G$			0.330			
		$y_G$			0.555			
	Blue	$x_B$			0.153			
		$y_B$			0.119			
Response Time (Rising + Falling)		$T_{RT}$	Ta = $25^\circ\text{C}$ $\Theta = 0^\circ$	-	12	16	ms	Note 6
Cross Talk		CT	$\Theta = 0^\circ$	-	-	2.0	%	Note 7

SPEC. NUMBER

SPEC. TITLE

PAGE

NT156FHM-N41 Product Specification Rev. O

9 OF 32

B2014-Q011-O (3/3)

A4(210 X 297)

<b>BOE</b>	PRODUCT GROUP	REV	ISSUE DATE
	Customer SPEC	Rev. 0	2016.01.12

## Notes :

1. Viewing angle is the angle at which the contrast ratio is greater than 10. The viewing angles are determined for the horizontal or 3, 9 o'clock direction and the vertical or 6, 12 o'clock direction with respect to the optical axis which is normal to the LCD surface (see FIGURE 1).

2. Contrast measurements shall be made at viewing angle of  $\Theta = 0$  and at the center of the LCD surface. Luminance shall be measured with all pixels in the view field set first to white, then to the dark (black) state .  
(see FIGURE 1) Luminance Contrast Ratio (CR) is defined mathematically.

$$CR = \frac{\text{Luminance when displaying a white raster}}{\text{Luminance when displaying a black raster}}$$

3. Center Luminance of white is defined as luminance values of 5 point average across the LCD surface. Luminance shall be measured with all pixels in the view field set first to white. This measurement shall be taken at the locations shown in FIGURE 2 for a total of the measurements per display.

4. The White luminance uniformity on LCD surface is then expressed as :  $\Delta Y = \text{Minimum Luminance of 5(or 13) points} / \text{Maximum Luminance of 5(or 13) points}$ .  
(see FIGURE 2 and FIGURE 3).

5. The color chromaticity coordinates specified in Table 5 shall be calculated from the spectral data measured with all pixels first in red, green, blue and white. Measurements shall be made at the center of the panel.

6. The electro-optical response time measurements shall be made as FIGURE 4 by switching the "data" input signal ON and OFF. The times needed for the luminance to change from 10% to 90% is  $T_r$ , and 90% to 10% is  $T_d$ .

7. Cross-Talk of one area of the LCD surface by another shall be measured by comparing the luminance (YA) of a 25mm diameter area, with all display pixels set to a gray level, to the luminance (YB) of that same area when any adjacent area is driven dark.  
(See FIGURE 5).

SPEC. NUMBER	SPEC. TITLE	PAGE
B2014-Q011-O (3/3)	NT156FHM-N41 Product Specification Rev. 0	10 OF 32

B2014-Q011-O (3/3)

A4(210 X 297)

**BOE**

PRODUCT GROUP

REV

ISSUE DATE

Customer SPEC

Rev. O

2016.01.12

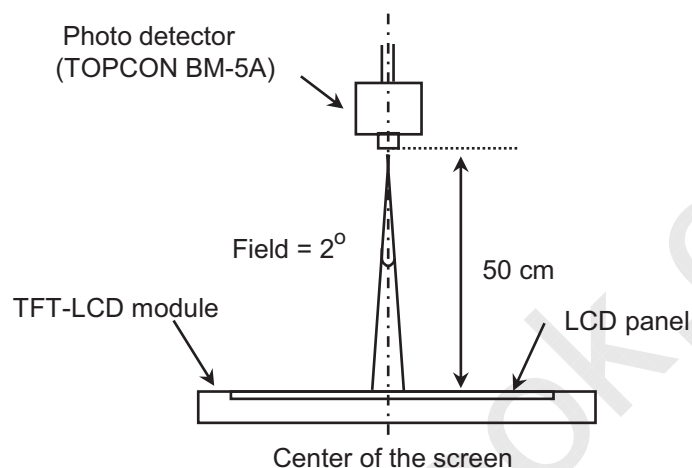
**4.3 Optical measurements****Figure 1. Measurement Set Up**

Optical characteristics measurement setup

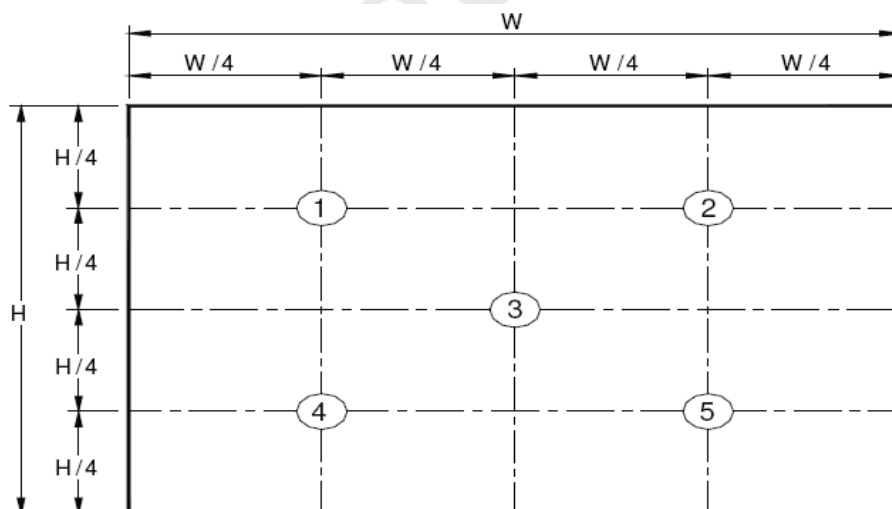
**Figure 2. White Luminance and Uniformity Measurement Locations (5 points)**

Center Luminance of white is defined as luminance values of center 5 points across the LCD surface. Luminance shall be measured with all pixels in the view field set first to white. This measurement shall be taken at the locations shown in FIGURE 2 for a total of the measurements per display.

SPEC. NUMBER

SPEC. TITLE

PAGE

NT156FHM-N41 Product Specification Rev. O

11 OF 32

B2014-Q011-O (3/3)

A4(210 X 297)

**BOE**

PRODUCT GROUP

REV

ISSUE DATE

Customer SPEC

Rev. O

2016.01.12

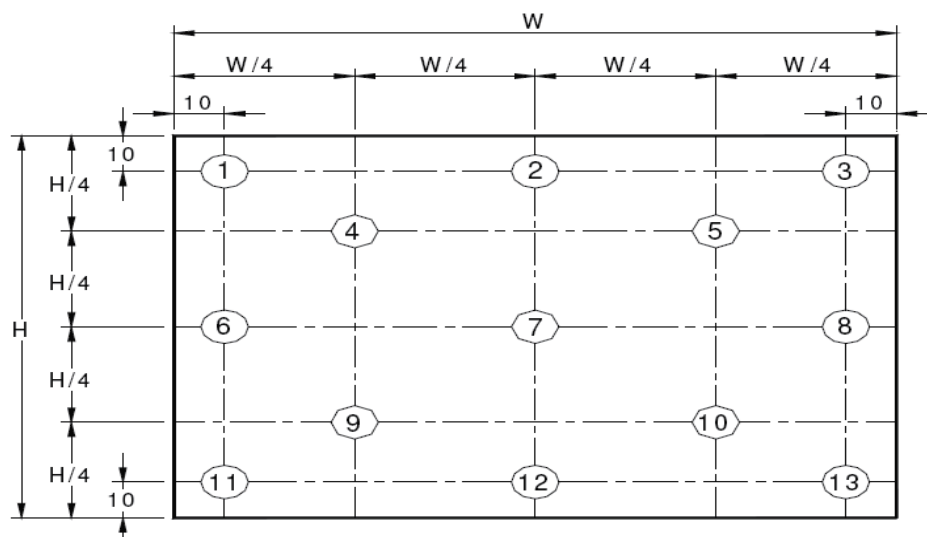
**Figure 3. Uniformity Measurement Locations (13 points)**

The White luminance uniformity on LCD surface is then expressed as :  $\Delta Y_5 = \text{Minimum Luminance of five points} / \text{Maximum Luminance of five points}$  (see FIGURE 2) ,  $\Delta Y_{13} = \text{Minimum Luminance of 13 points} / \text{Maximum Luminance of 13 points}$  (see FIGURE 3).

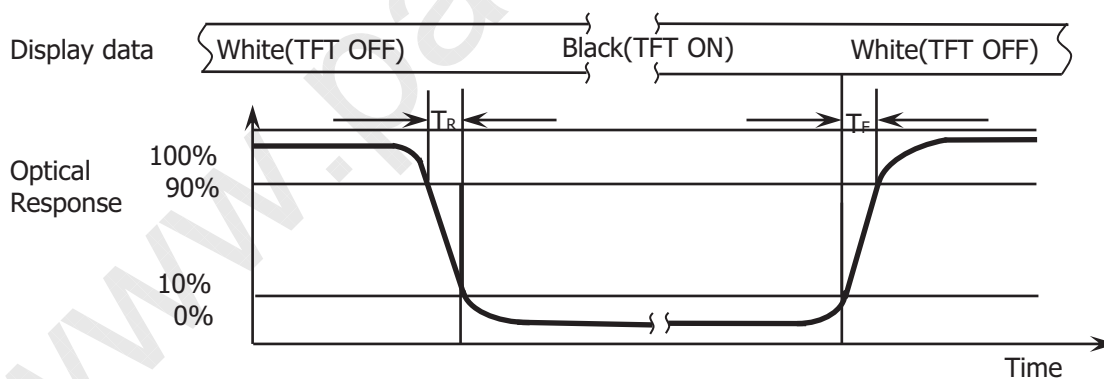
**Figure 4. Response Time Testing**

The electro-optical response time measurements shall be made as shown in FIGURE 4 by switching the "data" input signal ON and OFF. The times needed for the luminance to change from 10% to 90% is  $T_d$  and 90% to 10% is  $T_r$ .

SPEC. NUMBER

SPEC. TITLE

PAGE

NT156FHM-N41 Product Specification Rev. O

12 OF 32

B2014-Q011-O (3/3)

A4(210 X 297)

**BOE**

PRODUCT GROUP

REV

ISSUE DATE

Customer SPEC

Rev. O

2016.01.12

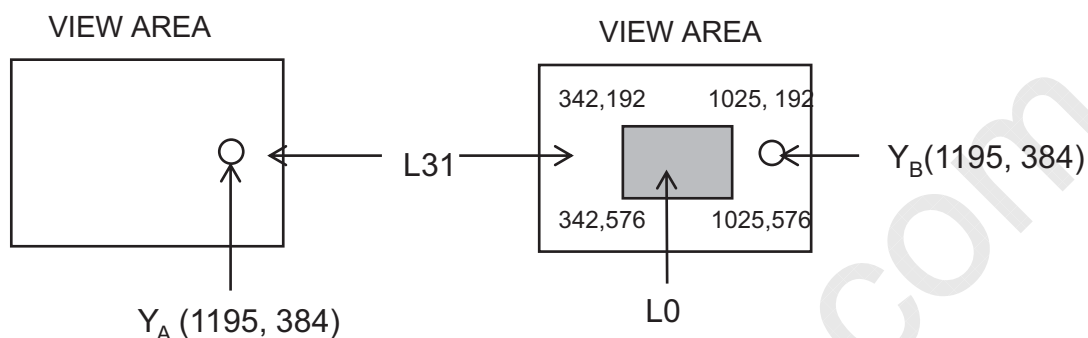
**Figure 5. Cross Modulation Test Description**

$$\text{Cross-Talk (\%)} = \left| \frac{Y_B - Y_A}{Y_A} \right| \times 100$$

Where:

 $Y_A$  = Initial luminance of measured area ( $\text{cd/m}^2$ ) $Y_B$  = Subsequent luminance of measured area ( $\text{cd/m}^2$ )

The location measured will be exactly the same in both patterns

Cross-Talk of one area of the LCD surface by another shall be measured by comparing the luminance ( $Y_A$ ) of a 25mm diameter area, with all display pixels set to a gray level, to the luminance ( $Y_B$ ) of that same area when any adjacent area is driven dark (Refer to FIGURE 5).

SPEC. NUMBER

SPEC. TITLE

PAGE

NT156FHM-N41 Product Specification Rev. O

13 OF 32

B2014-Q011-O (3/3)

A4(210 X 297)

**BOE**

PRODUCT GROUP

REV

ISSUE DATE

Customer SPEC

Rev. 0

2016.01.12

**5.0 INTERFACE CONNECTION.****5.1 Electrical Interface Connection**

The electronics interface connector is UJU IS050-L30B-C10 or Compatible.

The connector interface pin assignments are listed in Table 6.

&lt;Table 6. Pin Assignments for the Interface Connector&gt;

Terminal	Symbol	Functions
Pin No.	Symbol	Description
1	NC	No Connection
2	H_GND	Ground
3	LANE1_N	eDP RX channel 1 negative
4	LANE1_P	eDP RX channel 1 positive
5	H_GND	Ground
6	LANE0_N	eDP RX channel 0 negative
7	LANE0_P	eDP RX channel 0 positive
8	H_GND	Ground
9	AUX_CH_P	eDP AUX CH positive
10	AUX_CH_N	eDP AUX CH negative
11	H_GND	Ground
12	LCD_VCC	Power Supply, 3.3V (typ.)
13	LCD_VCC	Power Supply, 3.3V (typ.)
14	LCD_Self_Test	Panel self test enable
15	H_GND	Ground
16	H_GND	Ground
17	HPD	Hot plug detect output
18	BL_GND	LED Ground
19	BL_GND	LED Ground
20	BL_GND	LED Ground
21	BL_GND	LED Ground
22	BL_ENABLE	LED enable pin(+3.3V Input)
23	BL_PWM	System PWM Signal Input
24	NC	Reserved for LCD manufacturer's use
25	NC	Reserved for LCD manufacturer's use
26	BL_POWER	LED Power Supply 5V-21V
27	BL_POWER	LED Power Supply 5V-21V
28	BL_POWER	LED Power Supply 5V-21V
29	BL_POWER	LED Power Supply 5V-21V
30	NC	No Connection

SPEC. NUMBER

SPEC. TITLE

PAGE

NT156FHM-N41 Product Specification Rev. 0

14 OF 32

B2014-Q011-O (3/3)

A4(210 X 297)



<b>BOE</b>	PRODUCT GROUP	REV	ISSUE DATE
	Customer SPEC	Rev. 0	2016.01.12

**5-2. eDP Interface**

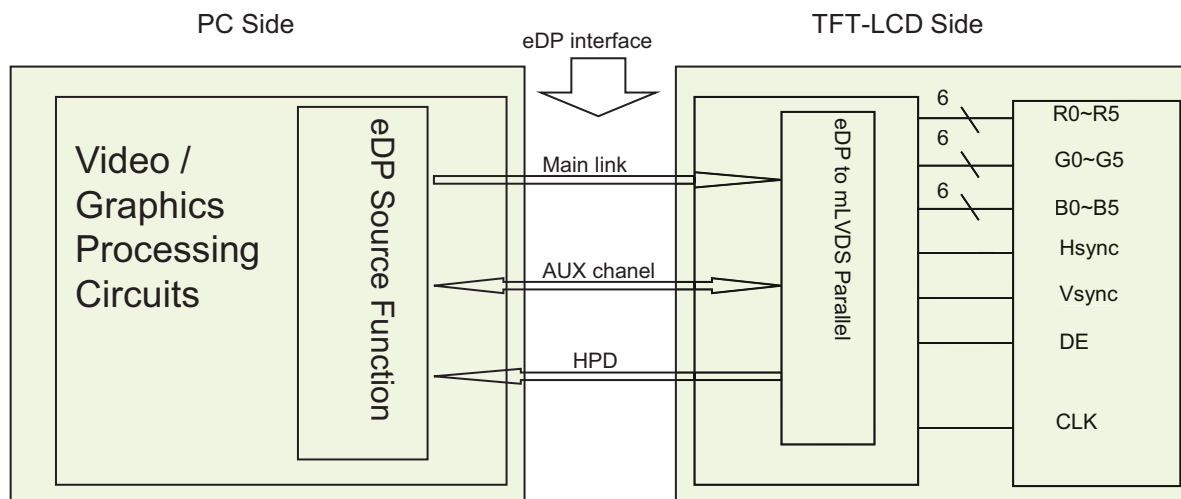

Note. Transmitter : Parade DP501 or equivalent.  
 Transmitter is not contained in Module.

SPEC. NUMBER	SPEC. TITLE	PAGE
	NT156FHM-N41 Product Specification Rev. 0	15 OF 32



<b>BOE</b>	PRODUCT GROUP	REV	ISSUE DATE
	Customer SPEC	Rev. O	2016.01.12

**5.3 Data Input Format**

<Table 6. Pin Assignments for the Interface Connector>

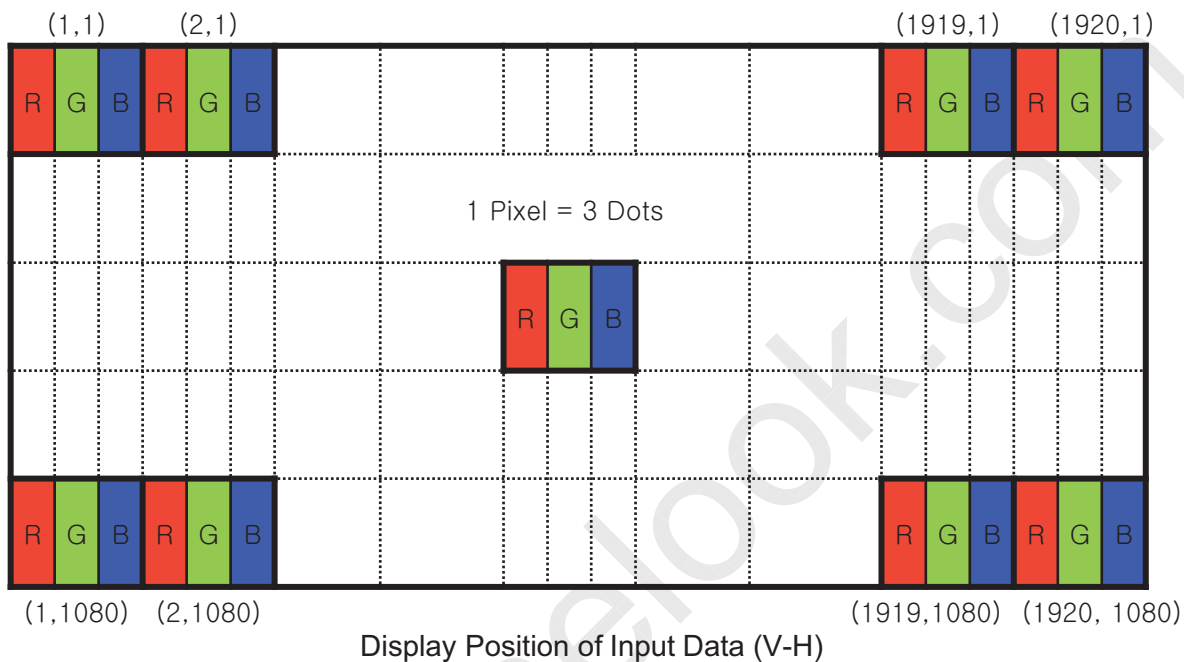

SPEC. NUMBER	SPEC. TITLE	PAGE
B2014-Q011-O (3/3)	NT156FHM-N41 Product Specification Rev. O	16 OF 32



**BOE**

PRODUCT GROUP

REV

ISSUE DATE

Customer SPEC

Rev. O

2016.01.12

**6.0 SIGNAL TIMING SPECIFICATION****6.1 The NT156FHM-N41 is operated by the DE only.**

Item		Symbols	Min	Typ	Max	Unit
Clock	Frequency	1/Tc	91.5	141.4	152.8	MHz
	High Time	Tch	-	4/7Tc	-	Tc
	Low Time	Tcl	-	4/7Tc	-	Tc
Frame Period		Tv	1100	1100	1120	lines
			40	60	62	Hz
			25	16.67	16.13	ms
Vertical Display Period		Tvd	-	1080	-	lines
One line Scanning Period		Th	2080	2142	2200	clocks
Horizontal Display Period		Thd	-	1920	-	clocks

SPEC. NUMBER

SPEC. TITLE

PAGE

NT156FHM-N41 Product Specification Rev. O

17 OF 32

B2014-Q011-O (3/3)

A4(210 X 297)

**BOE**

PRODUCT GROUP

REV

ISSUE DATE

Customer SPEC

Rev. 0

2016.01.12

**6.2 eDP Rx Interface Timing Parameter**

The specification of the eDP Rx interface timing parameter is shown in Table 8.

&lt;Table 8. eDP Rx Interface Timing Specification&gt;

Item	Symbol	Min	Typ	Max	Unit	Remark
Spread spectrum clock	ssc		0.5		%	
Differential peak-to-peak input voltage at package pins	VRX-DIFFp-p	100	0	1320	mV	
Rx input DC common mode voltage	VRX_DC_CM	-	GND	-	V	
Differential termination resistance	RRX-DIFF	80	-	100	$\Omega$	
Single-ended termination resistance	RRX-SE	40	-	60	$\Omega$	
Rx short circuit current limit	IRX_SHORT	-	-	20	mA	
Intra-pair skew at Rx package pins (HBR) RX intra-pair skew tolerance at HBR	LRX_SKEW_INTRA_PAIR	-	-	150	ps	

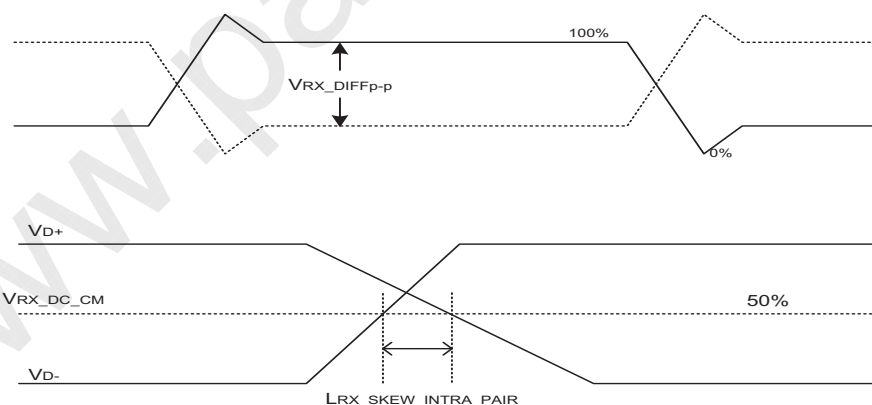

SPEC. NUMBER

SPEC. TITLE

PAGE

NT156FHM-N41 Product Specification Rev. 0

18 OF 32

B2014-Q011-O (3/3)

A4(210 X 297)



<b>BOE</b>	PRODUCT GROUP	REV	ISSUE DATE
	Customer SPEC	Rev. O	2016.01.12

### 7.0 INPUT SIGNALS, BASIC DISPLAY COLORS & GRAY SCALE OF COLORS

	Colors & Gray scale	Data signal																	
		R0	R1	R2	R3	R4	R5	G0	G1	G2	G3	G4	G5	B0	B1	B2	B3	B4	B5
Basic colors	Black	0	0	0	0	0	0	0	0	0	0	0	0	0	0	0	0	0	0
	Blue	0	0	0	0	0	0	0	0	0	0	0	0	1	1	1	1	1	1
	Green	0	0	0	0	0	0	1	1	1	1	1	1	0	0	0	0	0	0
	Light Blue	0	0	0	0	0	0	1	1	1	1	1	1	1	1	1	1	1	1
	Red	1	1	1	1	1	1	0	0	0	0	0	0	0	0	0	0	0	0
	Purple	1	1	1	1	1	1	0	0	0	0	0	0	1	1	1	1	1	1
	Yellow	1	1	1	1	1	1	1	1	1	1	1	1	0	0	0	0	0	0
	White	1	1	1	1	1	1	1	1	1	1	1	1	1	1	1	1	1	1
Gray scale of Red	Black	0	0	0	0	0	0	0	0	0	0	0	0	0	0	0	0	0	0
	△	1	0	0	0	0	0	0	0	0	0	0	0	0	0	0	0	0	0
	Darker	0	1	0	0	0	0	0	0	0	0	0	0	0	0	0	0	0	0
	△	↑						↑						↑					
	▽	↓						↓						↓					
	Brighter	1	0	1	1	1	1	0	0	0	0	0	0	0	0	0	0	0	0
	▽	0	1	1	1	1	1	0	0	0	0	0	0	0	0	0	0	0	0
Red	1	1	1	1	1	1	0	0	0	0	0	0	0	0	0	0	0	0	
Gray scale of Green	Black	0	0	0	0	0	0	0	0	0	0	0	0	0	0	0	0	0	0
	△	0	0	0	0	0	0	1	0	0	0	0	0	0	0	0	0	0	0
	Darker	0	0	0	0	0	0	0	1	0	0	0	0	0	0	0	0	0	0
	△	↑						↑						↑					
	▽	↓						↓						↓					
	Brighter	0	0	0	0	0	0	1	0	1	1	1	1	0	0	0	0	0	0
	▽	0	0	0	0	0	0	0	1	1	1	1	1	0	0	0	0	0	0
Green	0	0	0	0	0	0	1	1	1	1	1	1	0	0	0	0	0	0	
Gray scale of Blue	Black	0	0	0	0	0	0	0	0	0	0	0	0	0	0	0	0	0	0
	△	0	0	0	0	0	0	0	0	0	0	0	0	1	0	0	0	0	0
	Darker	0	0	0	0	0	0	0	0	0	0	0	0	0	1	0	0	0	0
	△	↑						↓						↑					
	▽	↓						↓						↓					
	Brighter	0	0	0	0	0	0	0	0	0	0	0	0	1	0	1	1	1	1
	▽	0	0	0	0	0	0	0	0	0	0	0	0	0	1	1	1	1	1
Blue	0	0	0	0	0	0	0	0	0	0	0	0	1	1	1	1	1	1	
Gray scale of White & Black	Black	0	0	0	0	0	0	0	0	0	0	0	0	0	0	0	0	0	0
	△	1	0	0	0	0	0	1	0	0	0	0	0	1	0	0	0	0	0
	Darker	0	1	0	0	0	0	0	1	0	0	0	0	0	1	0	0	0	0
	△	↑						↑						↑					
	▽	↓						↓						↓					
	Brighter	1	0	1	1	1	1	1	0	1	1	1	1	1	0	1	1	1	1
	▽	0	1	1	1	1	1	0	1	1	1	1	1	0	1	1	1	1	1
White	1	1	1	1	1	1	1	1	1	1	1	1	1	1	1	1	1	1	

SPEC. NUMBER	SPEC. TITLE	PAGE
B2014-Q011-O (3/3)	NT156FHM-N41 Product Specification Rev. O	19 OF 32



<b>BOE</b>	PRODUCT GROUP	REV	ISSUE DATE
	Customer SPEC	Rev. O	2016.01.12

### 8.0 POWER SEQUENCE

To prevent a latch-up or DC operation of the LCD module, the power on/off sequence shall be as shown in below

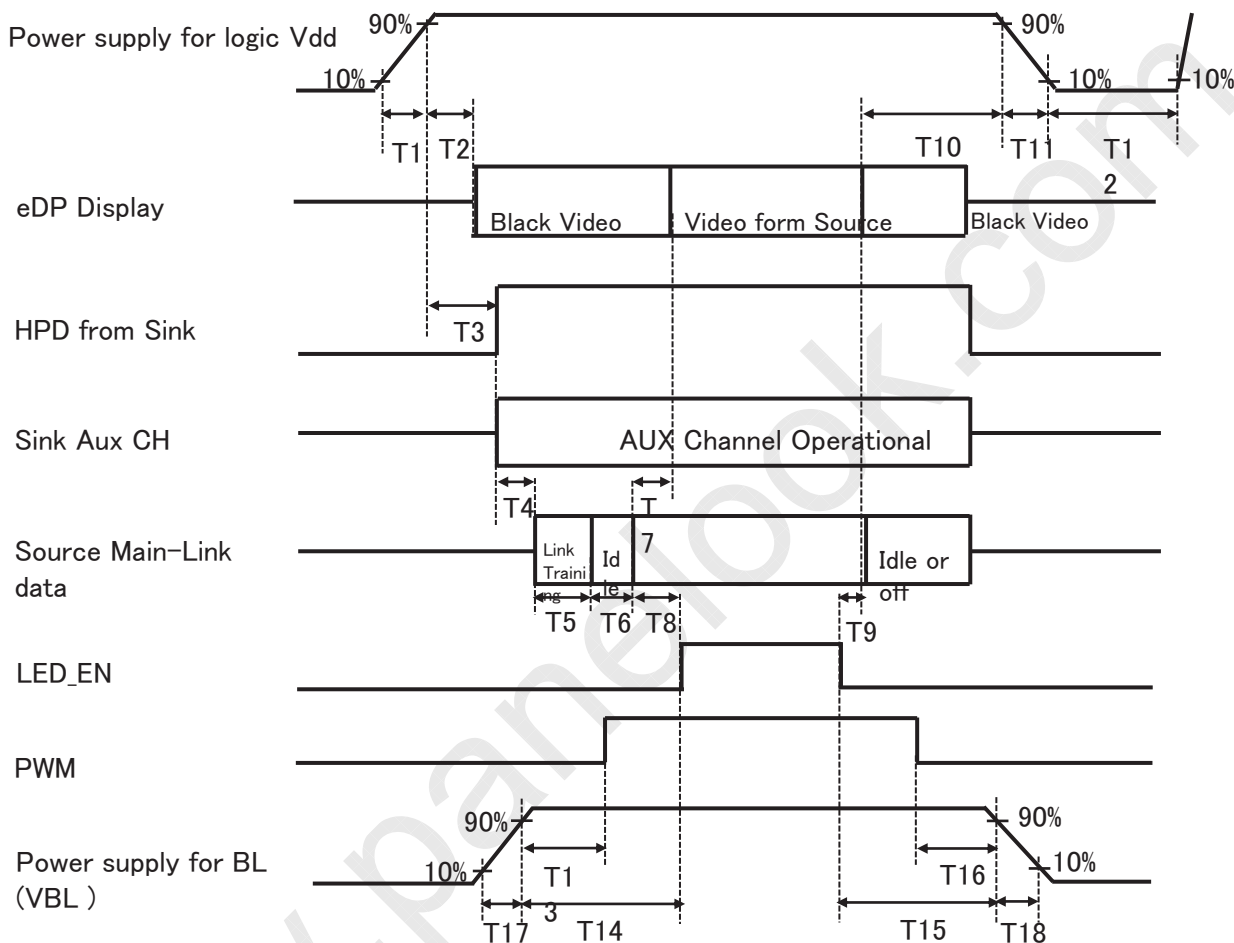

- 0.5ms ≤ T1 ≤ 10 ms
- 0ms ≤ T2 ≤ 200 ms
- 0ms ≤ T3 ≤ 200 ms
- 0ms ≤ T13
- 0ms ≤ T14
- 0ms ≤ T17
- 0ms ≤ T7 ≤ 50ms
- 0ms ≤ T10 ≤ 500 ms
- 0ms ≤ T11 ≤ 10 ms
- 150ms ≤ T12
- 0ms ≤ T15
- 0ms ≤ T16
- 0ms ≤ T18

**Notes:**

1. When the power supply VDD is 0V, keep the level of input signals on the low or keep high impedance.
2. Do not keep the interface signal high impedance when power is on. Back Light must be turn on after power for logic and interface signal are valid.

SPEC. NUMBER	SPEC. TITLE	PAGE
	NT156FHM-N41 Product Specification Rev. O	20 OF 32

**BOE**

PRODUCT GROUP

REV

ISSUE DATE

Customer SPEC

Rev. 0

2016.01.12

**9.0 Connector Description**

Physical interface is described as for the connector on LCM.

These connectors are capable of accommodating the following signals and will be following components.

**9.1 TFT LCD Module**

Connector Name /Description	For Signal Connector
Manufacturer	UJU or Compatible
Type/ Part Number	IS050-L30B-C10 or Compatible
Mating housing/ Part Number	I-PEX 20454-030T or Compatible

SPEC. NUMBER

SPEC. TITLE

PAGE

NT156FHM-N41 Product Specification Rev. 0

21 OF 32

B2014-Q011-O (3/3)

A4(210 X 297)

**BOE**

PRODUCT GROUP

REV

ISSUE DATE

Customer SPEC

Rev. 0

2016.01.12

## 10.0 MECHANICAL CHARACTERISTICS

### 10.1 Dimensional Requirements

FIGURE 6 shows mechanical outlines for the model NT156FHM-N41.  
Other parameters are shown in Table 9.

<Table 9. Dimensional Parameters>

Parameter	Specification	Unit
Active Area	344.16 (H) × 193.59 (V)	
Number of pixels	1920 (H) X 1080 (V) (1 pixel = R + G + B dots)	
Pixel pitch	0.17925 (H) X 0.17925 (V)	
Pixel arrangement	RGB Vertical stripe	
Display colors	262K	
Display mode	Normally white	
Dimensional outline	359.5(H)*223.8(V) (W/PCB)*3.2(Max) 359.5 (H)×206.5(V)×3.2 (max)	mm
Weight	370 (max)	gram

### 10.2 Mounting

See FIGURE 6.

### 10.3 Anti-Glare and Polarizer Hardness.

The surface of the LCD has an AG coating to minimize reflection and a coating to reduce scratching.

### 10.4 Light Leakage

There shall not be visible light from the back-lighting system around the edges of the screen as seen from a distance 50cm from the screen with an overhead light level of 350lux.

SPEC. NUMBER

SPEC. TITLE

PAGE

NT156FHM-N41 Product Specification Rev. 0

22 OF 32

B2014-Q011-O (3/3)

A4(210 X 297)

**BOE**

PRODUCT GROUP

REV

ISSUE DATE

Customer SPEC

Rev. O

2016.01.12

**11.0 RELIABILITY TEST**

The Reliability test items and its conditions are shown in below.

&lt;Table 10. Reliability test&gt;

No	Test Items	Conditions
1	High temperature storage test	Ta = 60 °C, 240 hrs
2	Low temperature storage test	Ta = -20 °C, 240 hrs
3	High temperature & high humidity operation test	Ta = 50 °C, 80%RH, 240 hrs
4	High temperature operation test	Ta = 50 °C, 240 hrs
5	Low temperature operation test	Ta = 0 °C, 240 hrs
6	Thermal shock	Ta = -20 °C ↔ 60 °C (0.5 hr), 100 cycle
7	Vibration test (non-operating)	1.5G, 10~500Hz, Half Sine X,Y,Z / Sweep rate : 1 hour
8	Shock test (non-operating)	220G, Half Sine Wave 2msec ±X, ±Y, ±Z Once for each direction
9	Electro-static discharge test (non-operating)	Air : 150 pF, 330Ω, 15 KV Contact : 150 pF, 330Ω, 8 KV

**12.0 HANDLING & CAUTIONS**

## (1) Cautions when taking out the module

- Pick the pouch only, when taking out module from a shipping package.

## (2) Cautions for handling the module

- As the electrostatic discharges may break the LCD module, handle the LCD module with care. Peel a protection sheet off from the LCD panel surface as slowly as possible.
- As the LCD panel and back - light element are made from fragile glass material, impulse and pressure to the LCD module should be avoided.
- As the surface of the polarizer is very soft and easily scratched, use a soft dry cloth without chemicals for cleaning.
- Do not pull the interface connector in or out while the LCD module is operating.
- Put the module display side down on a flat horizontal plane.
- Handle connectors and cables with care.

## (3) Cautions for the operation

- When the module is operating, do not lose CLK, ENAB signals. If any one of these signals is lost, the LCD panel would be damaged.
- Obey the supply voltage sequence. If wrong sequence is applied, the module would be damaged.

SPEC. NUMBER

SPEC. TITLE

PAGE

NT156FHM-N41 Product Specification Rev. O

23 OF 32

B2014-Q011-O (3/3)

A4(210 X 297)

<b>BOE</b>	PRODUCT GROUP	REV	ISSUE DATE
	Customer SPEC	Rev. O	2016.01.12

- (4) Cautions for the atmosphere
  - Dew drop atmosphere should be avoided.
  - Do not store and/or operate the LCD module in a high temperature and/or humidity atmosphere. Storage in an electro-conductive polymer packing pouch and under relatively low temperature atmosphere is recommended.
- (5) Cautions for the module characteristics
  - Do not apply fixed pattern data signal to the LCD module at product aging.
  - Applying fixed pattern for a long time may cause image sticking.
- (6) Other cautions
  - Do not disassemble and/or re-assemble LCD module.
  - Do not re-adjust variable resistor or switch etc.
  - When returning the module for repair or etc., Please pack the module not to be broken. We recommend to use the original shipping packages.

### 13.0 LABEL

#### (1) Product label

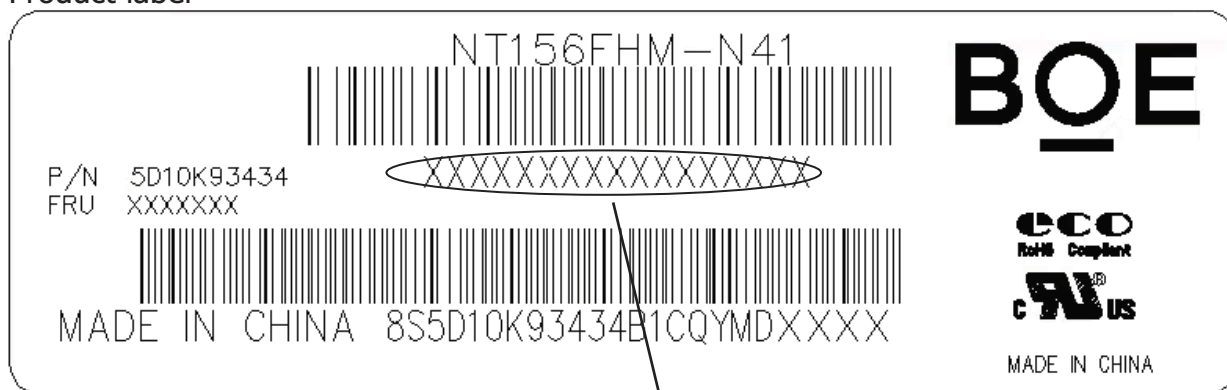

Module ID Naming Rule:

Digit	1	2	3	4	5	6	7	8	9	10	11	12	13	14	15	16	17
Code	S	L	S	5	1	2	3	5	9	4	2	0	0	0	1	D	B
Description	Model Code /GBN		Grade	Line	Year		Month	Model Extension Code (Last 4 Digits Of FGCOD)				Serial No 00001-ZZZZZZ					

SPEC. NUMBER	SPEC. TITLE	PAGE
B2014-Q011-O (3/3)	NT156FHM-N41 Product Specification Rev. O	24 OF 32





<b>BOE</b>	PRODUCT GROUP	REV	ISSUE DATE
	Customer SPEC	Rev. O	2016.01.12

(2) High voltage caution label

	HIGH VOLTAGE CAUTION	COLD CATHODE FLUORESCENT LAMP IN LCD PANEL CONTAINS A SMALL AMOUNT OF MERCURY. PLEASE FOLLOW LOCAL OR- DINANCES OR REGULATIONS FOR DISPOSAL.
	RISK OF ELECTRIC SHOCK, DISCONNECT THE ELECTRIC POWER BEFORE SERVICING	

(3) Box label

**BOE**
CHONGQING BOE OPTOELECTRONICS  
TECHNOLOGY Co., LTD

MODEL: XXXXXXX-XXX ①	Q'TY: XX ②
SERIAL NO: XXXXXXXXXXXX ③	DATE: XXXXXXXX ④

BOX ID 条形码

XXXXXXXXXX ⑤
XXXX ⑥
XXXX ⑦

序列号标注部分需打印, 说明如下:

1. **FG-CODE**(前12位)                      2. 产品数量
3. **Box ID**                                      4. 包装日期
5. 客户端段物料号(客户端)---暂不打印
6. FG-Code后四位
7. 供应商代码 ---暂不打印
8. **Total Size:100×50mm**

Digit Code	1	2	3	4	5	6	7	8	9	10	11	12	13
Code	S	L	S	5	1	2	3	D	0	0	0	6	8
Description	Products GBN		Grade	Line	Year		Month	Revisio n Code	SerialNo				

SPEC. NUMBER	SPEC. TITLE	PAGE
	NT156FHM-N41 Product Specification Rev. O	25 OF 32

<b>BOE</b>	PRODUCT GROUP	REV	ISSUE DATE
	Customer SPEC	Rev. O	2016.01.12

## 14.0 PACKING INFORMATION

### 15.1 Packing order

- Put Pad into the inner box

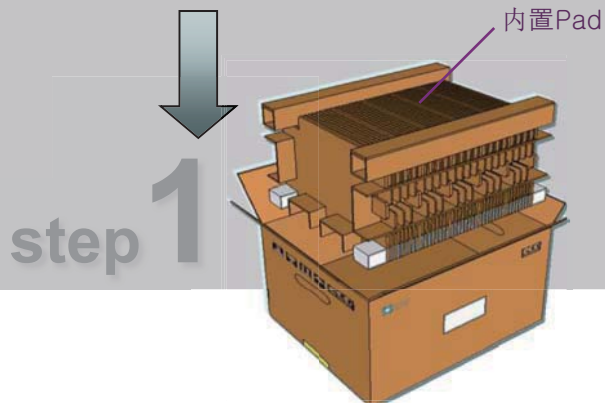

- Put module into the paper spacer and modules bundled by PE Bag

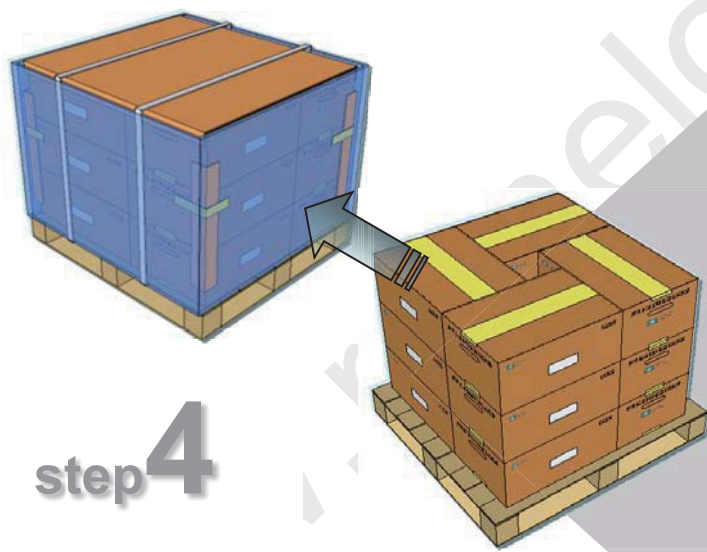
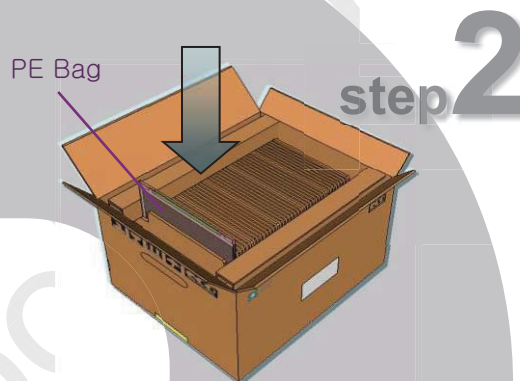

- Put Cover on the top of the pad

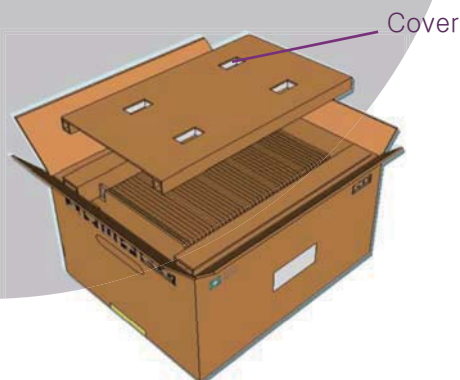

- 12ea Box/Pallet, 456ea MDL/Pallet

### 15.2 Notes

- Box Dimension:
- Package Quantity in one Box: pcs
- Total Weight: kg

SPEC. NUMBER	SPEC. TITLE	PAGE
B2014-Q011-O (3/3)	NT156FHM-N41 Product Specification Rev. O	26 OF 32

BOE

PRODUCT GROUP

REV

ISSUE DATE

Customer SPEC

Rev. O

2016.01.12

## 15.0 MECHANICAL OUTLINE DIMENSION

Figure 6. TFT-LCD Module Outline Dimension (Front View)

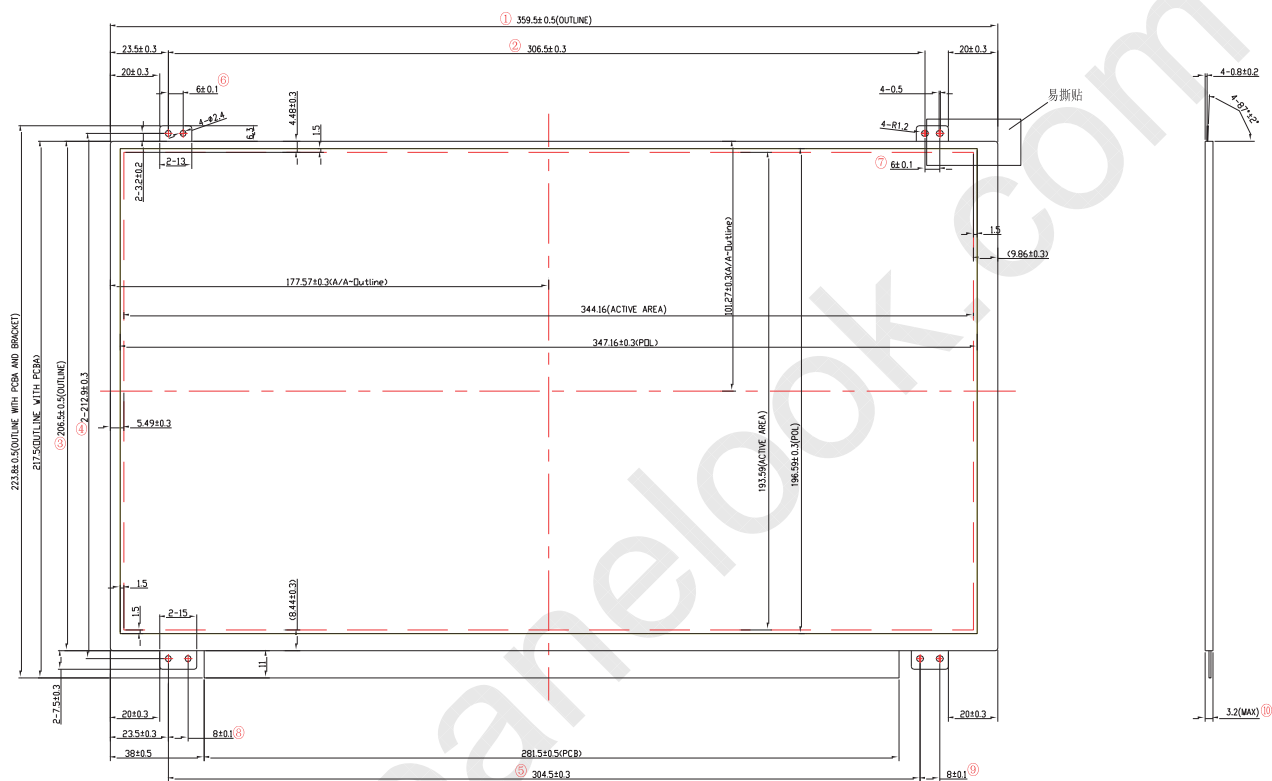

SPEC. NUMBER

SPEC. TITLE

PAGE

NT156FHM-N41 Product Specification Rev. O

27 OF 32

B2014-Q011-O (3/3)

A4(210 X 297)

<b>BOE</b>	PRODUCT GROUP	REV	ISSUE DATE
	Customer SPEC	Rev. 0	2016.01.12

Figure 7. TFT-LCD Module Outline Dimensions (Rear view)

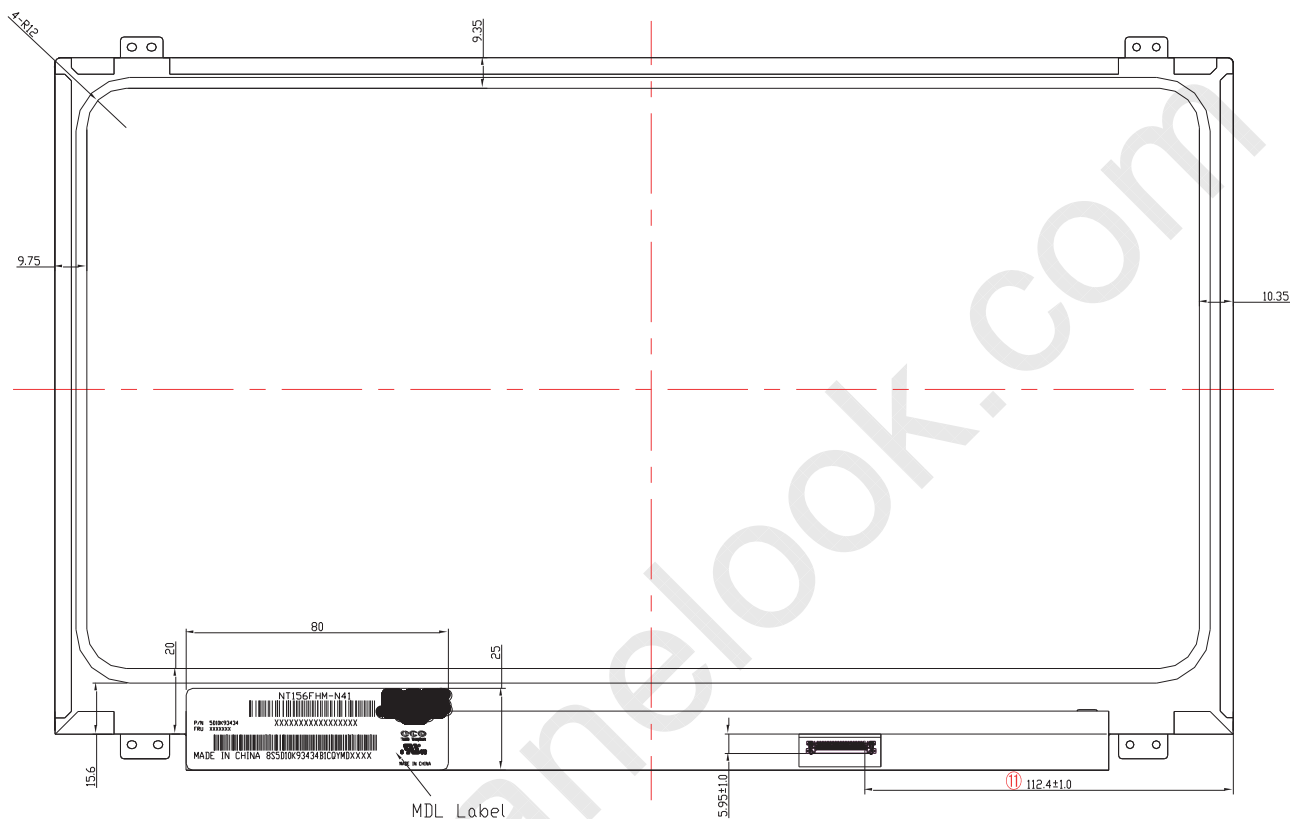

SPEC. NUMBER	SPEC. TITLE	PAGE
B2014-Q011-O (3/3)	NT156FHM-N41 Product Specification Rev. 0	28 OF 32

B2014-Q011-O (3/3)

A4(210 X 297)

**BOE**

PRODUCT GROUP

REV

ISSUE DATE

Customer SPEC

Rev. O

2016.01.12

**16.0 EDID Table**

Address (HEX)	Function	Hex		Dec	Input values	Notes
00	Header	00	0		0	EDID Header
01		FF	255		255	
02		FF	255		255	
03		FF	255		255	
04		FF	255		255	
05		FF	255		255	
06		FF	255		255	
07		00	0		0	
08	ID Manufacturer Name	09	9		BOE	ID = BOE
09		E5	229			
0A	ID Product Code	BA	186		1722	ID = 1722
0B		06	6			
0C	32-bit serial No.	00	0			
0D		00	0			
0E		00	0			
0F		00	0			
10	Week of manufacture	01	1		1	
11	Year of Manufacture	1A	26		2016	Manufactured in 2016
12	EDID Structure Ver.	01	1		1	EDID Ver 1.0
13	EDID revision #	04	4		4	EDID Rev. 0.4
14	Video input definition	95	149		-	digital signal/DP input
15	Max H image size	22	34		34	34 cm (Approx)
16	Max V image size	13	19		19	19 cm (Approx)
17	Display Gamma	78	120		2.2	Gamma curve = 2.2
18	Feature support	02	2			RGB display, Preferred Timming mode/RGB 4:4:4
19	Red/Green low bits	B0	176		-	Red / Green Low Bits
1A	Blue/White low bits	90	144		-	Blue / White Low Bits
1B	Red x high bits	97	151	606	0.592	Red (x) = 10010111 (0.592)
1C	Red y high bits	58	88	355	0.347	Red (y) = 01011000 (0.347)
1D	Green x high bits	54	84	336	0.329	Green (x) = 01010100 (0.329)
1E	Green y high bits	92	146	584	0.571	Green (y) = 10010010 (0.571)
1F	Blue x high bits	26	38	154	0.151	Blue (x) = 00100110 (0.151)
20	Blue y high bits	1D	29	117	0.115	Blue (y) = 00011101 (0.115)
21	White x high bits	50	80	320	0.313	White (x) = 01010000 (0.313)
22	White y high bits	54	84	336	0.329	White (y) = 01010100 (0.329)
23	Established timing 1	00	0		-	
24	Established timing 2	00	0		-	

SPEC. NUMBER

SPEC. TITLE

PAGE

NT156FHM-N41 Product Specification Rev. O

29 OF 32

B2014-Q011-O (3/3)

A4(210 X 297)

**BOE**

PRODUCT GROUP

REV

ISSUE DATE

Customer SPEC

Rev. O

2016.01.12

25	Established timing 3	00	0	-	
26	Standard timing #1	01	1		Not Used
27		01	1		
28	Standard timing #2	01	1		Not Used
29		01	1		
2A	Standard timing #3	01	1		Not Used
2B		01	1		
2C	Standard timing #4	01	1		Not Used
2D		01	1		
2E	Standard timing #5	01	1		Not Used
2F		01	1		
30	Standard timing #6	01	1		Not Used
31		01	1		
32	Standard timing #7	01	1		Not Used
33		01	1		
34	Standard timing #8	01	1		Not Used
35		01	1		
36	Detailed timing/monitor descriptor #1	3C	60	141.4	141.4MHz Main clock
37		37	55		
38		80	128	1920	Hor Active = 1920
39		DE	222	222	Hor Blanking = 222
3A		70	112	-	4 bits of Hor. Active + 4 bits of Hor. Blanking
3B		38	56	1080	Ver Active = 1080
3C		14	20	20	Ver Blanking = 20
3D		40	64	-	4 bits of Ver. Active + 4 bits of Ver. Blanking
3E		30	48	48	Hor Sync Offset = 48
3F		20	32	32	H Sync Pulse Width = 32
40		36	54	3	V sync Offset = 3 line
41		00	0	6	V Sync Pulse width : 6 line
42		58	88	344	Horizontal Image Size = 344 mm (Low 8 bits)
43		C1	193	193	Vertical Image Size = 193 mm (Low 8 bits)
44		10	16	-	4 bits of Hor Image Size + 4 bits of Ver Image Size
45		00	0	0	Hor Border (pixels)
46	00	0	0	Vertical Border (Lines)	
47	1A	26		Refer to right table	

SPEC. NUMBER

SPEC. TITLE

PAGE

NT156FHM-N41 Product Specification Rev. O

30 OF 32

B2014-Q011-O (3/3)

A4(210 X 297)

BOE		PRODUCT GROUP				REV	ISSUE DATE
		Customer SPEC				Rev. O	2016.01.12
48	Detailed timing/monitor descriptor #2	00	0		0.0	0MHz Main clock	
49		00	0				
4A		00	0		0	Hor Active = 0	
4B		00	0		0	Hor Blanking = 0	
4C		00	0		-	4 bits of Hor. Active + 4 bits of Hor. Blanking	
4D		00	0		0	Ver Active = 768	
4E		00	0		0	Ver Blanking = 0	
4F		00	0		-	4 bits of Ver. Active + 4 bits of Ver. Blanking	
50		00	0		0	Hor Sync Offset = 0	
51		00	0		0	H Sync Pulse Width = 0	
52		00	0		0	V sync Offset = 0 line	
53		00	0		0	V Sync Pulse width : 0 line	
54		00	0		0	Horizontal Image Size = 0 mm (Low 8 bits)	
55		00	0		0	Vertical Image Size = 0 mm (Low 8 bits)	
56		00	0		-	4 bits of Hor Image Size + 4 bits of Ver Image Size	
57		00	0		0	Hor Border (pixels)	
58		00	0		0	Vertical Border (Lines)	
59		00	0				
5A		Detailed timing/monitor descriptor #3	00	0			ASCII Data Sting Tag
5B	00		0				
5C	00		0				
5D	FE		254				
5E	00		0				
5F	42		66		B	Manufacture name : BOECQ	
60	4F		79		O		
61	45		69		E		
62	20		32				
63	43		67		C		
64	51	81		Q			
65	0A	10					
66	20	32					
67	20	32					
68	20	32					
69	20	32					
6A	20	32					
6B	20	32					
SPEC. NUMBER		SPEC. TITLE				PAGE	
B2014-Q011-O (3/3)		NT156FHM-N41 Product Specification Rev. O				31 OF 32	
						A4(210 X 297)	



<b>BOE</b>	PRODUCT GROUP	REV	ISSUE DATE
	Customer SPEC	Rev. O	2016.01.12

6C	Detailed timing/monitor descriptor #4	00	0			Product Name Tag (ASCII)
6D		00	0			
6E		00	0			
6F		FE	254			
70		00	0			
71		4E	78		N	Model name : NT156FHM-N41
72		54	84		T	
73		31	49		1	
74		35	53		5	
75		36	54		6	
76	46	70		F		
77	48	72		H		
78	4D	77		M		
79	2D	45		-		
7A	4E	78		N		
7B	34	52		4		
7C	31	49		1		
7D	0A	10				
7E	Extension flag	00	0			
7F	Checksum	FF	255	255	-	

SPEC. NUMBER	SPEC. TITLE	PAGE
	NT156FHM-N41 Product Specification Rev. O	32 OF 32